

SURFDAYS

Your Pop-Up
Surf-Station



Outdoor Setup



Stadtwerke Karlsruhe



Parkdeck Spandau Arcaden Berlin

SURFDAYS

Indoor Setup



Glacis Galerie Neu-Ulm



Interboot Messe Friedrichshafen

SURFDAYS

Rent incl. operations



basic offer 4 Tdays incl. Set up and logistics

Reception Desk "Tiki Bar"
Changing Room, wetsuits, towels
Surf-Instructors
Booking / Registration
Photo / Video-Documentation
PR and Social Media
2 days setup; 1 day breakdown
incl. logistics

4 operating days 31.300€
maximum duration: 10 days 42.836€
only available in DACH region

SURFDAYS

Lease/ Sales



incl. Pool 13,5 x 7 meter
Entrance 4 x 2 meters + 2 stairs
filtration / PH / redox handling
2 + 1 Boards
Set up and training (1 day)

client:

Water (40 cbm)/Power (3x32 CEE)

lease 3 Months 45.000€
Sales price 174.500€
Lease gets fully counted
in case of returning 9.000€
cleaning / logistics fee

Surf-Days
www.surf-days.com

Calculation



Item	cost / unit	remark
Rider / Session	3,0	capacity: 5
Duration / Session (h)	0,5	
Rider / Hour	6	
Contribution/Rider net	15,00 €	Maximum: 20 €
Revenue / Hour	12,61 €	
Operating Hours / Day	75,63 €	
Revenue / Day	8,0	
Personell (1 Person)	605,04 €	
Energy / Day 40 kwh x 51 Cent	200,00 €	
Water 1 cbm	163,20 €	
Contribution Margin I.	2,00 €	
Operating Days p.y.	239,84 €	
Contribution Margin I. p.a.	220	
Invest 174 KEUR	52.765,24 €	
Break Even after	2,84	years
ROI under conservative estimation of life cycle in %	89.326,22 €	min. 5 years
	51%	

SURFDAYS

Target Group

Suitable for Alle
From beginner to sportsman.
No matter wich age.
Fun in stand up surfing,
kneeboarding or bodysurfing.



Spontaneous bookings
walk arounds and unplanned
visits wich become attracted
by your location and our
uncommon wave machine.



Lifestyle-, music- and
fashion-seeking
young adults.
Snow-, Skate-,
Surf interest holders.



Kids being the decision
takers for the entire
familij.



Viral due to quick learning
progress: The teacher
trains the surf student with
his hands and you crash
soft.

SURFDAYS

Air, Water

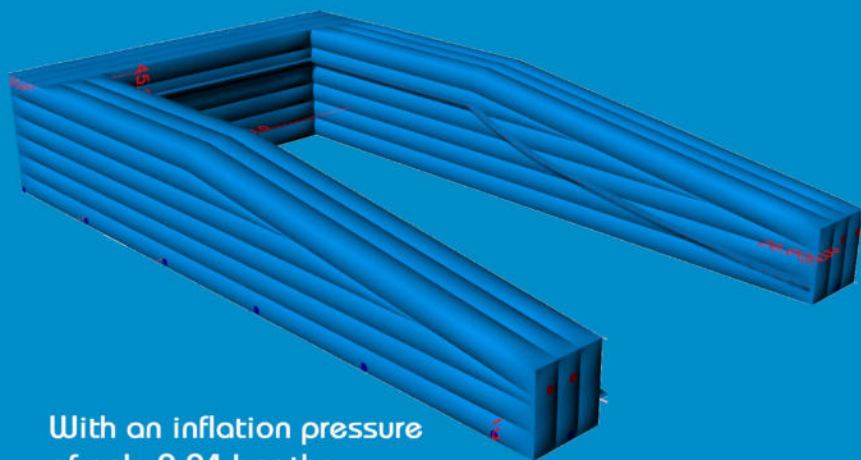

With an inflation pressure of only 0,04 bar the surf-area is shaped. The pressure is controlled with a pump between 25 und 45 mBar.



An event pool (included in our product) made from durable PVC and steel brackets contains 40 cbm water. A filtration system with water conditioning chlorine and PH completes the system. All 4 weeks we recommend changing the water to provide perfect conditions to your customers.

SURFDAYS

and power.

Registered design and registered international patent: Our unique pump-construction:

- 3 Pumps à 15 KW / 32 CEE-plug
- Maximum energy efficiency: no deflections
- 1.500 rpm. and silent by engineering
- 35 km/h slow flow = authentic feeling

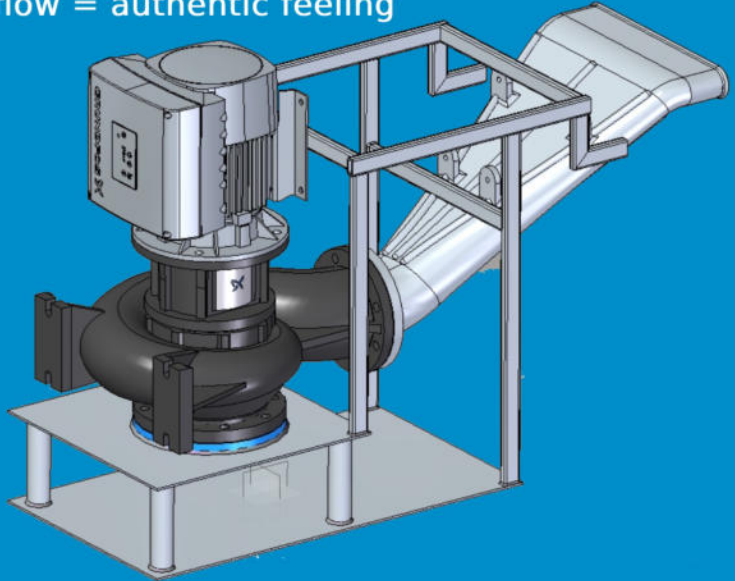

GRUNDFOS 



Plug and Surf

- Simple handling via one controller
- Service and 3year warranty via global market leader Grundfos

SURFDAYS

About us



The **founder**

10 years FMCG experience
2 years strategy consulting
Windsurfer, Surfer, Kiteboarder, Wingfoiler

The **Company**

2001 founded in owner-proprietorship
2004 Change into GmbH & Co.KG
2022 Split off into 2 independent GmbH (comparable to Ltd.)

The **Brand**

2002 first kiteboarding event followed German-
and European Championships
2008 first Wakeboard-Event and 2012-2021
owned 2 pole mobile cable
2005 first Surf-Event and since 2016
development Surf-Days
2018 Registration Surf-Days as name mark brand
with european protection scope for
trademark categories 25 (fashion),
28 (fun rides) and 41 (Events)



SURFDAYS

Specials

individually branded **Deck Chairs** corresponding Din EN 581-2:

- 60 pcs. digital printing ca. 25€
- 700 pcs. screen printing ca. 15€



Surf-Simulator (starting 210€ / day or 8.300€ purchase)

- High frequency
- Also for the youngest guests suitable
- Eye Catcher



SURFDAYS

Sommer, Sonne, Strand

Brand Guides

Markenberatung



© Brand Guides GmbH
Fon +49 (0) 40 54 80 23 0
Fax +49 (0) 40 54 80 23 29

Steilshooper Strasse 112
22305 Hamburg
#SommerSonneStrand

info@brandguides.com